



HIAB ix.138 HIDUO

BASIC DATA

HIAB iX.138 HIDUO

BASIC DATA

Technical data	HIAB iX.138 HIDUO B-2	HIAB iX.138 HIDUO BS-2	HIAB iX.138 HIDUO BSS-2	HIAB iX.138 HIDUO B-3
Mdyn (kNm)	158	158	158	159
Max. lifting capacity (kNm)	127	128	129	124
Lifting capacity (tm)	13.0	13.1	13.2	12.7
Outreach – lifting capacity, standard (m–kg)	8.6 – 1480	8.3 – 1540	7.7 – 1700	10.7 – 1080
Outreach – lifting capacity, manual extensions (m–kg)	10.7 – 1120	10.4 – 1180	–	12.9 – 840
Hydraulic outreach, standard (m)	8.8	8.5	7.9	11
Outreach, manual extensions (m)	10.7	10.7	–	13.2
Lifting height above installation level, hydr/man (m)	11.2 / 13.4	10.9 / 13.1	10.3	13.4 / 15.6
Rec. fixed oil flow (l/min)	45 – 55			
Rec. variable oil flow (l/min)	–			
Working pressure (Mpa)	32.1			
Oil in tank (l)	70 – 200			
Oil in Cyclon tank (l)	57			
Tank capacity (l)	82 – 235			
Tank capacity Cyclon (l)	61			
Slewing angle (°)	415			
Max slope viable at full capacity (°)	6.4			
Slewing torque, gross (kNm)	21.6			
Slewing speed 80 (°/s)	15			
Slewing speed (°/s)	–			
Lifting speed at standard hydraulic outreach (m/s)	1.7	1.6	1.5	2.1
Height in folded position (mm)	2264			
Width in folded position (mm)	2476	2452	2476	2476
Install space required with hose and pipe kit (mm)	834			942
Crane in standard version without stabiliser system (kg)	1490	1490	1450	1620
Frame attachments (kg)	26			
Stabiliser system (kg)	216 – 383			

This table shows a few examples of models, and represents some of all options available. With the opportunity to configure your crane, we can provide you with a crane perfectly tailored to your needs.

Please contact your local dealer for more information on the variety of options we can offer.

HIAB iX.138 HIDUO

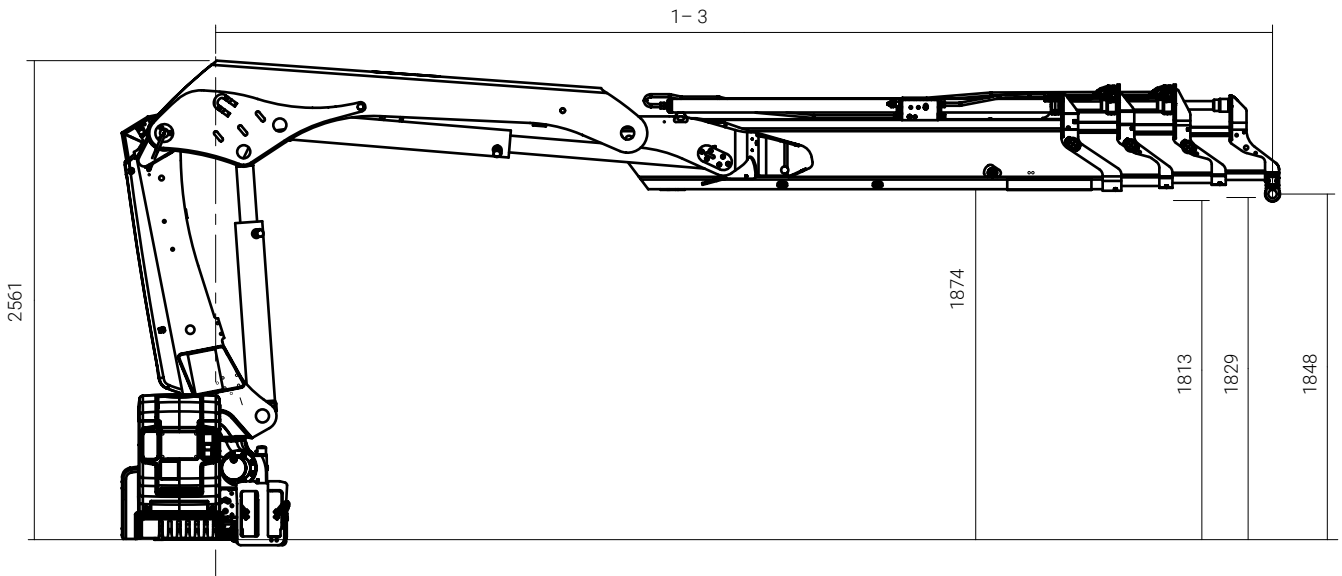

1-3, OUTREACH				
Ext.	Hyd. ext.		+ Man. ext.	
	Min	Max	Min	Max
B-3	5049	10999	5049	10999
B-2	4964	8814	4964	8814
B-1	4879	6779	4879	6779

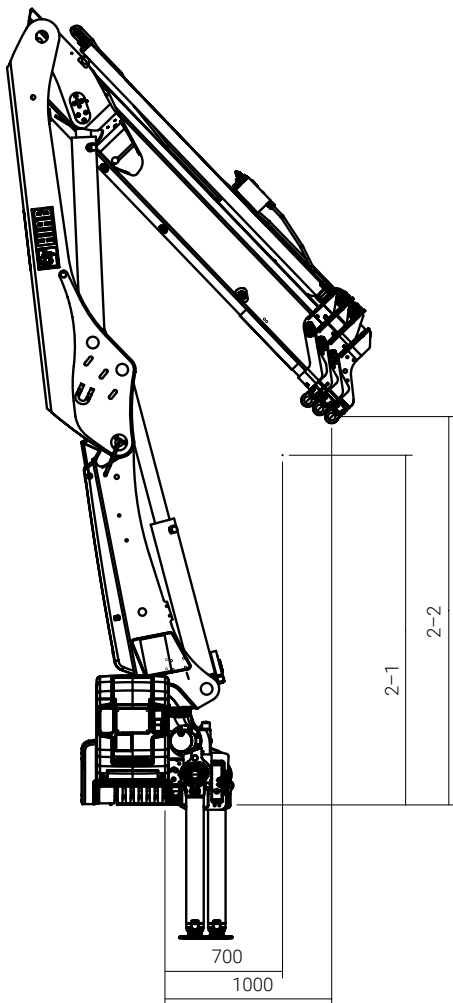

Hook position – close

EXTENSION	2-1	2-2
BS-3	2479	2717
BS-2	2580	2830
BS-1	2680	2946

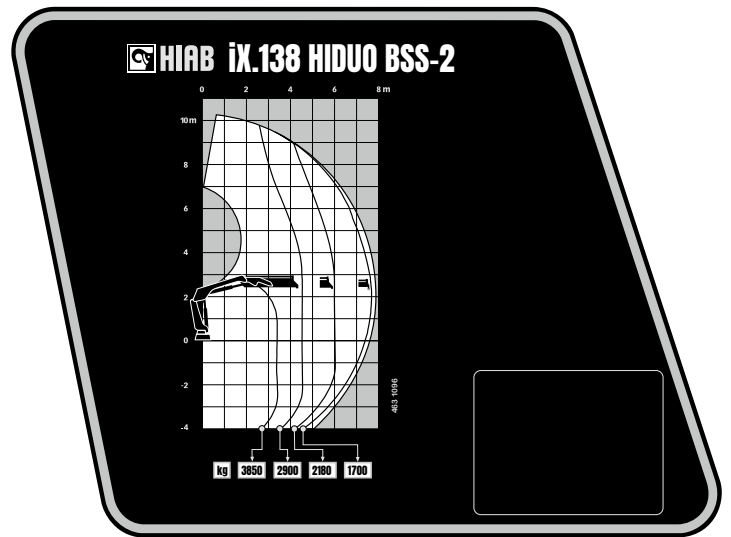
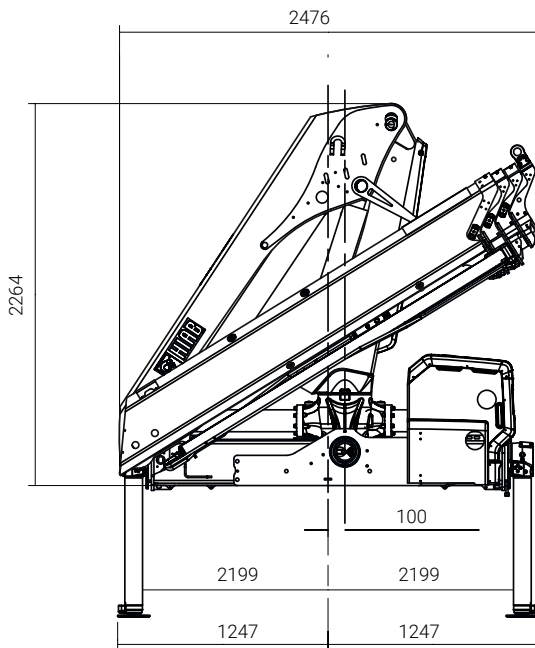

Disclaimer. We reserve the right to make changes. Illustrations, drawings and data are not always in accordance with the latest version or standard model in production. The models in the pictures may present special equipment or colours.

BUILT TO PERFORM

Hiab is a leading provider of smart and sustainable load handling solutions. We are committed to delivering the best customer experience every day with the most engaged people and partners. Hiab's premium equipment includes HIAB, EFFER and ARGOS loader cranes, MOFFETT and PRINCETON truck mounted forklifts, LOGLIFT forestry cranes, JONSERED recycling cranes, MULTILIFT skiploaders and hooklifts, GALFAB roll-off cable hoists, and tail lifts under the ZEPRO, DEL and WALTCO brands. As the industry pioneer, Hiab continues to make load handling smarter, safer and more sustainable to build a better tomorrow.

Hiab is part of Cargotec Corporation.

www.hiab.com

